

Spare Parts List

SG 135/92



2007

0-5500-123

MACHINE ASSEMBLIES

		page
1	13,5HP ENGINE ASSEMBLY	2
2	FRONT AXLE	4
3	STEERING	6
4	18" TRANSMISSION DRIVE	8
5	OPERATION-MOWER/LIFT	10
6	CUTTING PAN-MOWER HOUSING COMPL.	12
7	OPERATION TRAVEL PEDALS	14
8	OPERATION BRAKE	16
9	ELECTRICAL WIRING HARNESS COMPL.	18
10	BODY ASSY FENDER SEAT	20
10	BODY ASSEMBLY HOOD	22
11	GRASS COLLECTOR ASSY.	24
12	CHUTE COLLECTOR ASSEMBLY	26
14	DECALS LABELS	28
15	FRAME	30

ENGINE ASSEMBLY

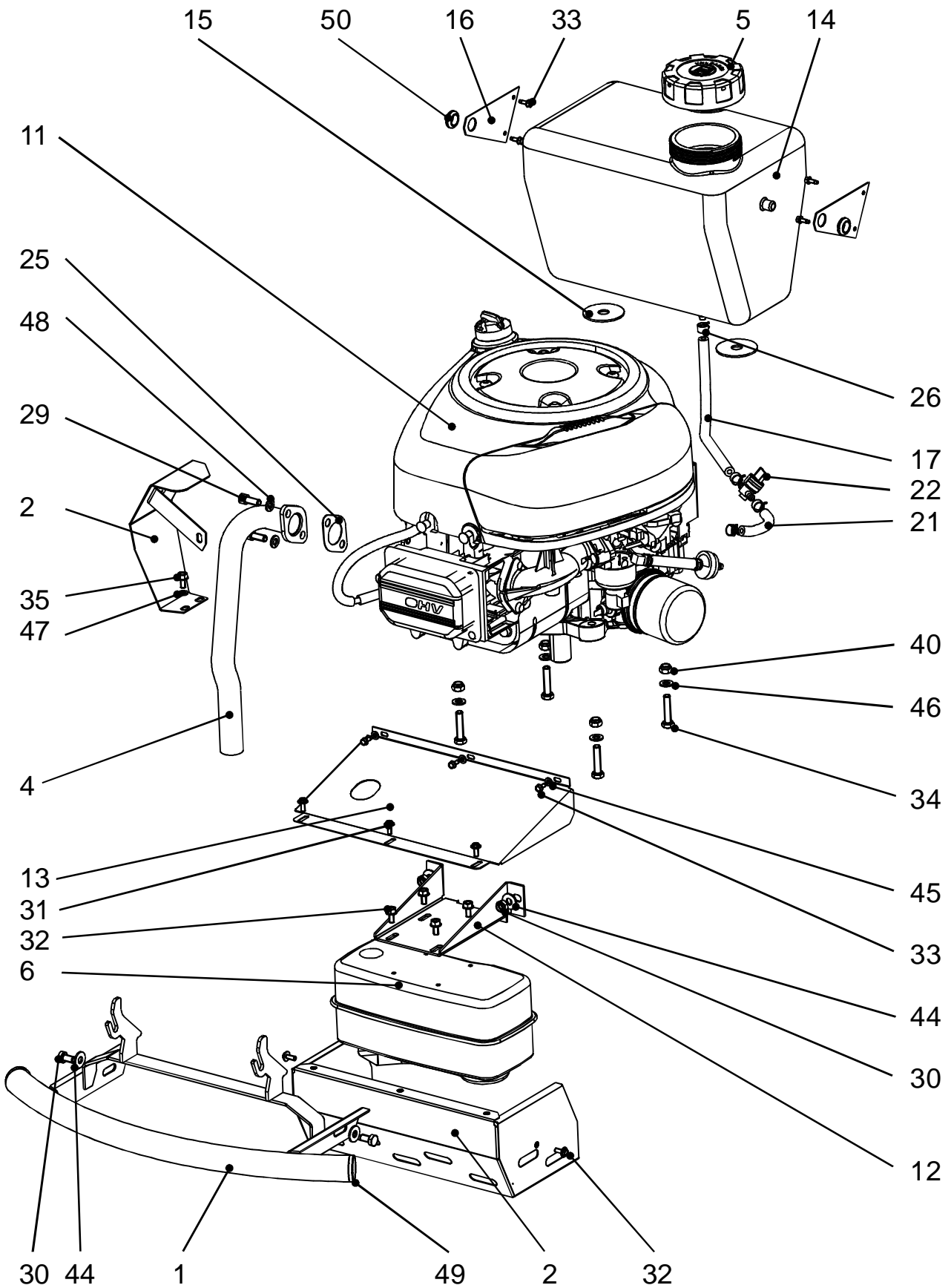

ASSEMBLY "1"

13,5HP ENGINE ASSEMBLY

position	part no.	name	qty.	drawing no.
1	207 956 256	BUMPER	1	9-5600-256
2	207 956 252	PIPE COVER	1	9-5600-252
3	207 956 250	EXHAUST PIPE COVER	1	9-5600-250
4	207 956 257	COLLECTING PIPE B+S 13,5HP	1	9-5600-257
5	204 958 052	KARSIT TANK COVER	1	9-5800-052
6	505 900 053	EXHAUST SILENCER 15,5 HP	1	
11	206 100 442	INTEK ENGINE 13,5HP AVS 21B9770198 E	1	
12	207 055 028	EXHAUST PIPE HOLDER	1	0-5500-028
13	207 055 038	TOP COVER	1	0-5500-038
14	207 055 016	8L TANK	1	0-5500-016
15	207 055 010	WASHER	2	0-5500-010
16	207 055 015	CLAMP	2	0-5500-015
17	207 056 847	FUEL HOSE	1	0-5600-847
21	000 008 646	FUEL HOSE	1	1-9920-227
22	000 476 300	FUEL COCK 493960	1	0-5900-111
25	000 224 180	GASKET INTEK 15,5/17 HP INTEK	1	
26	000 318 164	CLAMP UM 5008	4	
29	000 201 531	HEX SCREW 5/16"-18 UNC-3/4LG	2	
30	000 243 441	HEX SCREW M8x16 DIN 933-8,8	2	
31	505 900 065	HEX SCREW M6x12 DIN 7500 D	5	
32	000 259 094	SCREW M5x12 eco-fix 4,8	5	
33	000 259 314	SCREW 4,2x13 eco-drill DIN 7504 K	7	
34	000 299 530	HEX SCREW M8x35 DIN 933-8,8	4	
40	000 280 885	NUT M8 DIN 985-KL.8	6	
44	000 298 760	WASHER 8,4 DIN 9021 B	4	
46	000 291 500	WASHER 8,4 DIN 125 A	4	
47	000 298 210	WASHER 6,4 DIN 9021B	1	
48	000 200 442	WASHER 8 DIN 127 B	2	
49	207 100 456	CAPPING GL 32x0,8-2,5	2	
50	207 100 454	BUSH KD3 21/13-7	2	

FRONT AXLE

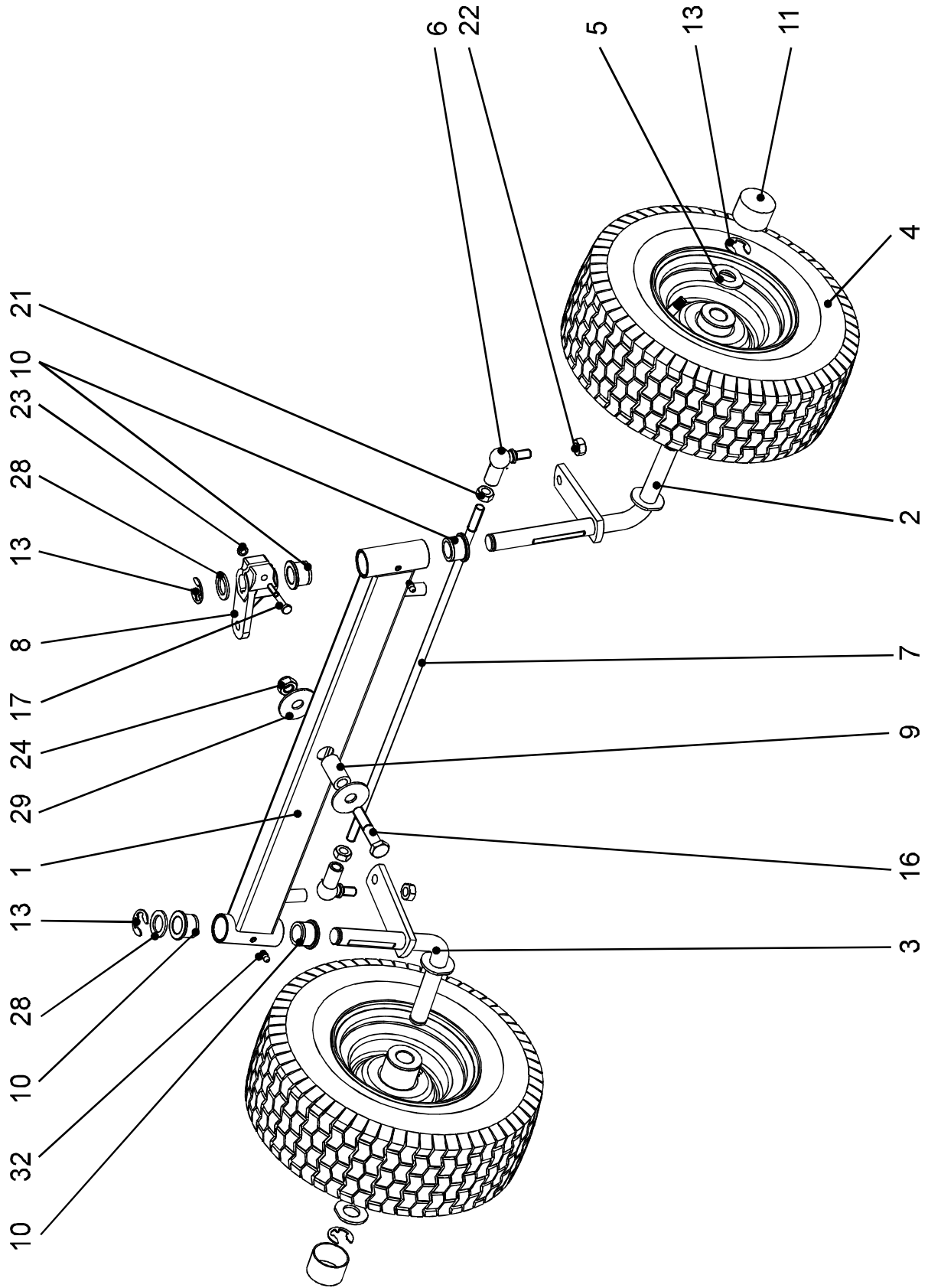

ASSEMBLY "2"

FRONT AXLE 13"

position	part no.	name	qty.	drawing no.
13"				
1	206 056 291	AXLE BEAM	1	9-5600-291
2	206 956 293	LEFT PIN 13"	1	9-5600-293
3	206 956 292	RIGHT PIN 13"	1	9-5600-292
4	206 959 337	WHEEL 13x5,00-6 TS	2	9-5900-337
5	000 096 349	WASHER 19	2	0-9220-739
6	195 800 901	BALL JOINT DIN 71802CS BOSSARD	2	9-5800-901
7	206 056 839	CONNECTING ROD	1	0-5600-839
8	200 058 647	STEERING LEVER	1	0-5800-647
9	206 056 838	SPACER	1	0-5600-838
10	206 056 837	VERTICAL PIN CASE	4	0-5600-837
11	000 407 121	CAP SC1 1/2	2	
13	000 230 230	STIRRUP RING 15 DIN 6799	4	
16	207 204 158	HEX SCREW M12x60 DIN 931-8.8	1	
17	201 221 175	HEX SCREW M6x45 DIN 931-8.8	1	
21	000 273 625	NUT M 10 DIN 934	2	
22	204 101 006	NUT M10 DIN 980 8/V	2	
23	000 281 446	NUT M6 DIN 985 KI.8	2	
24	000 282 577	NUT M12 DIN 985 KI.8	1	
28	000 295 966	WASHER 19 DIN125A	2	
29	207 036 164	WASHER 13 DIN 440 R	2	
32	000 740 113	LUBRICATING NIPPLE MK6 DIN71 412	2	
33	000 207 152	SPRING 5x7.5 DIN 6888	1	

STEERING

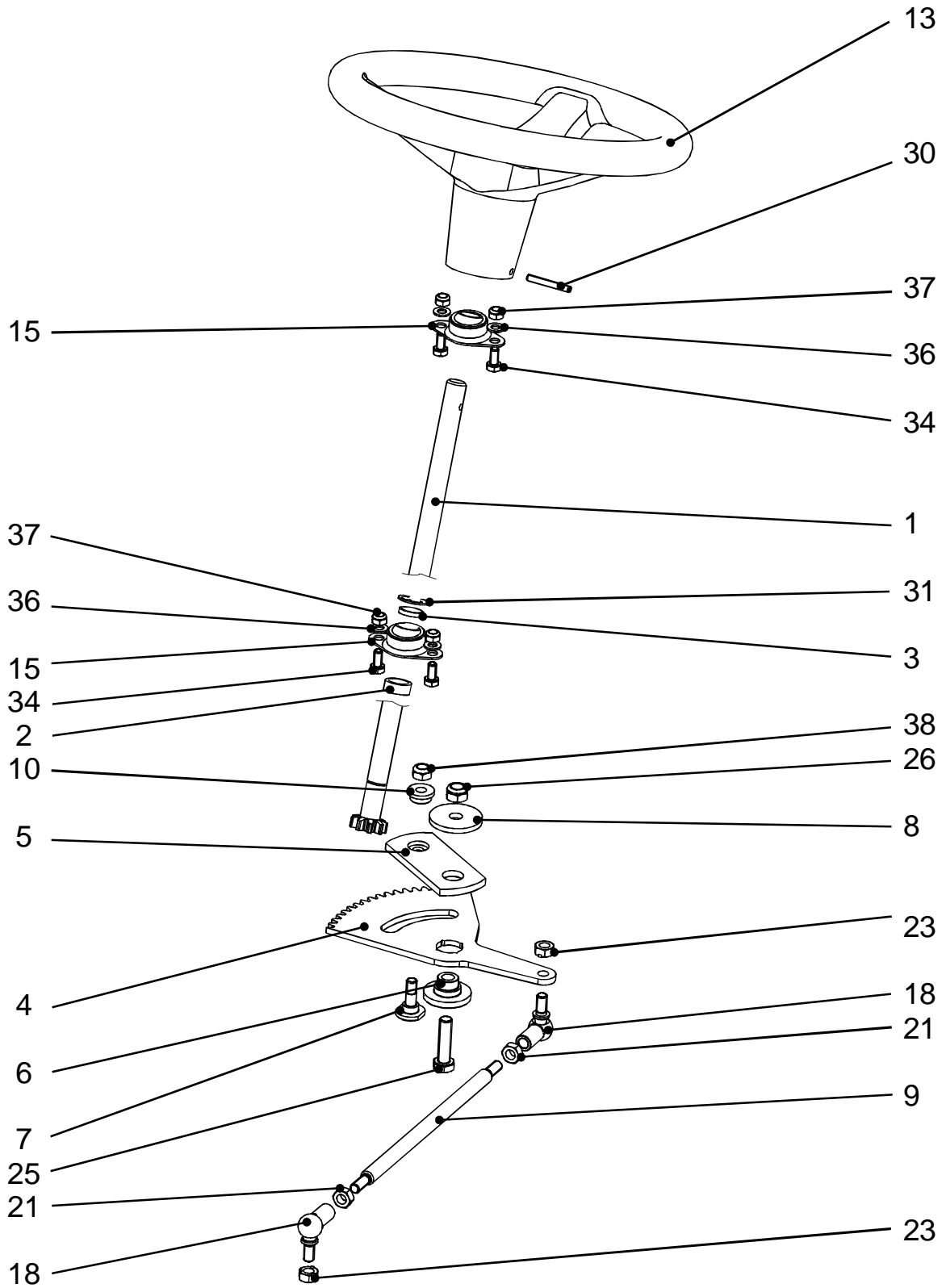

ASSEMBLY "3"

STEERING

position	part no.	name	qty.	drawing no.
1	207 956 401	STEERING WHEEL SHAFT	1	9-5600-401
2	105 800 969	BOTTOM CASE	1	0-5800-969
3	105 800 970	TOP CASE	1	0-5800-970
4	206 056 849	TOOTHED SEGMENT	1	0-5600-849
5	201 058 248	STEERING PLATE	1	0-5800-248
6	201 058 247	STEERING PIN	1	0-5800-247
7	201 058 246	SHOULDER BOLT	1	0-5800-246
8	505 900 043	STEERING WASHER	1	0-5800-245
9	206 056 850	STEERING ROD	1	0-5600-850
10	201 058 244	CASE	1	0-5800-244
13	204 958 063	KARSIT STEERING WHEEL	1	9-5800-063
15	505 900 002	JOINT BEARING FJB 12	2	0-5900-002
18	195 800 901	BALL JOINT 16	2	9-5800-901
19	000 235 246	WIRE LOCK 16 DIN 71805 S	1	
21	000 273 625	NUT M10 DIN 934 KI.8	2	
23	204 101 006	SECURING NUT M10 DIN 980 8/V	2	
25	220 012 045	HEX SCREW M12x45 DIN 933-8.8	1	
30	204 160 001	SPIRAL PIN 6x45 ISO 8750	1	
31	000 230 230	STIRRUP 15 DIN 6799	1	
34	000 243 441	HEX SCREW M8x16 DIN 933-8.8	2	
36	000 291 500	WASHER 8,4 DIN 125 A	6	
37	000 280 885	NUT M8 DIN 985 KI.8	4	
38	000 281 446	NUT M10 DIN 985 KI.8	1	

TRANSMISSION DRIVE

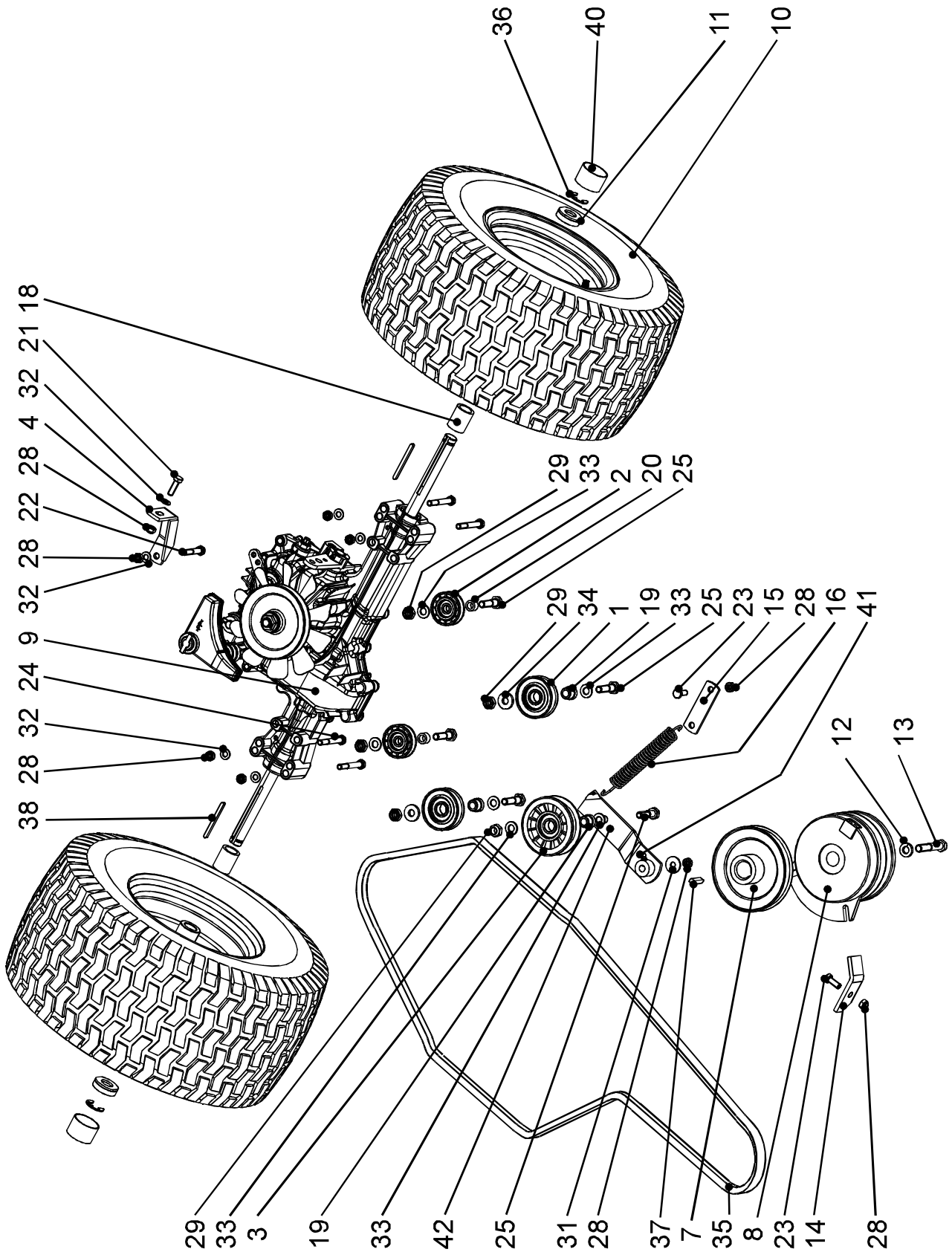

ASSEMBLY "4"

18" TRANSMISSION DRIVE

position	part no.	name	qty.	drawing no.
1	207 059 349	BELT PULLEY V 2500-2740 (CAPITOL)	2	0-5900-349
2	207 059 350	BELT PULLEY 2" VIP 2000-2112	1	0-5900-350
3	000 786 445	TENSIONING BELT PULLEY	1	0-5900-070
4	207 956 251	REACTION CATCH	1	9-5600-251
7	200 959 137	ENGINE BELT PULLEY 4,65"	1	9-5900-137
8	000 892 595	ELMG. CLUTCH MSS 80C 5217-9	1	9-5900-071
9	208 959 061	GEAR BOX K-46 (TUFF TORQ)	1	9-5900-061
10	207 959 336	WHEEL 18x8,50-8 4PR	2	9-5900-336
11	204 958 041	WASHER 19 WITH SHOULDER RING	2	9-5800-041
12	000 276 012	WASHER 7/16"- HEAVY DESIGN	1	0-5900-062
13	000 294 833	CLUTCH BOLT 7/16"-20x2 1/2LG	1	0-5900-005
14	207 055 009	CLUTCH ARRESTING FOOT	1	0-5500-009
15	207 055 008	SPRING FOOT	1	0-5500-008
16	200 058 260	TORO TRAVEL SPRING	1	0-5800-260
17	000 096 349	WASHER	2	0-9220-739
18	200 058 432	SPACER HYDRO TT	2	0-5800-432
19	000 091 993	CASE	2	0-9421-418
20	207 055 004	SPACER	2	0-5500-004
21	000 246 235	SCREW M8x25 DIN 933-8,8	1	
22	201 852 073	SCREW M8x45 DIN 931-10.9	1	
23	000 244 563	SCREW M8x20 DIN 933-8,8	4	
24	200 225 405	SCREW M8x60 DIN 931-8,8	4	
25	000 238 414	SCREW M10x40 DIN 931-8.8	4	
28	000 280 885	NUT M8 DIN 985-KL.8	9	
29	000 281 446	NUT M10 DIN 985-KL.8	4	
31	000 298 760	WASHER 8,4 DIN 9021 B	1	
32	000 291 500	WASHER 8.4 DIN 125A	11	
33	000 292 061	WASHER 10.5 DIN 125A	4	
34	201 852 454	WASHER 10.5 DIN 7349	2	
35	207 100 448	WEDGE BELT A 96 Li 243	1	
36	000 230 230	RETAINING RING 15 DIN 6799	2	
37	000 273 955	SPRING 1/4"x1/4"x1 1/4"	1	
38	000 299 299	SPRING 3/16"x3/16"x2 1/2"	2	
40	000 407 121	CAP SC 1 1/2	2	
41	000 740 113	LUBRICATING NIPPLE MK6 DIN 71 412	1	
42	207 956 243	TENSIONER ARM		9-5600-243

OPERATION - MOWER / LIFT

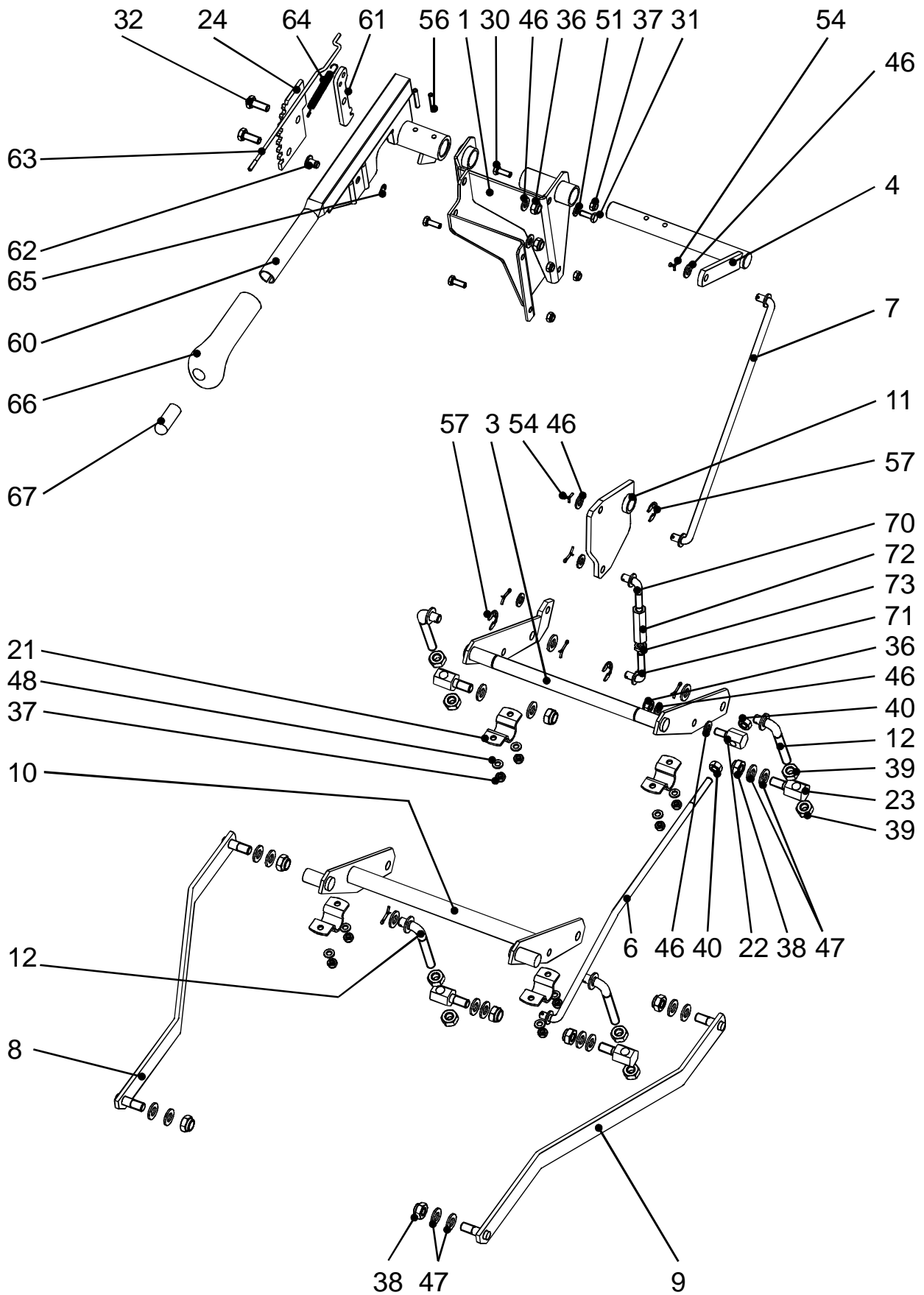

ASSEMBLY "5"

OPERATION-MOWER/LIFT

position	part no.	name	qty.	drawing no.
1	207 956 343	CONSOLE	1	9-5600-343
3	207 956 344	REAR SUSPENSION	1	9-5600-344
4	207 956 347	LIFTING SHAFT	1	9-5600-347
6	207 956 351	COMPLETE ROD	1	9-5600-351
7	207 956 352	CONNECTING ROD	1	9-5600-352
8	207 956 353	COMPLETE ROD "P"	1	9-5600-353
9	207 956 354	COMPLETE ROD "L"	1	9-5600-354
10	207 956 355	FRONT SUSPENSION	1	9-5600-355
11	207 956 356	COMPLETE ROCKER	1	9-5600-356
12	207 956 357	MOWING SUSPENSION	1	9-5600-357
21	207 056 927	STIRRUP	1	0-5600-927
22	207 056 928	SUSPENSION PIN	2	0-5600-928
23	207 056 929	SUSPENSION PIN	4	0-5600-929
24	207 056 930	TOOTHED SEGMENT	1	0-5600-930
30	000 247 357	HEX SCREW M6x12 DIN 933-8.8	4	
31	000 284 449	HEX SCREW M6x16 DIN 933-8,8	1	
32	000 244 563	HEX SCREW M8x20 DIN 933-8,8	2	
36	000 280 885	NUT M8 DIN 985-KL.8	7	
37	000 283 118	NUT M6 DIN 985-KL.8	12	
38	000 281 446	NUT M10 DIN 985-KL.8	12	
39	000 273 625	NUT M10 DIN 934-KL.8	4	
40	000 272 503	NUT M8 DIN 934-KL.8	2	
46	000 291 500	WASHER 8.4 DIN 125A	12	
47	000 292 061	WASHER 10.5 DIN 125A	20	
48	000 290 389	WASHER 6.4 DIN 125 A	8	
51	000 200 442	WASHER 6 DIN 127 B	1	
54	200 282 218	COTTER PIN 2x18 DIN 94	10	
56	000 324 467	PIN 5x30 DIN 1481	2	
57	000 324 467	STIRRUP 12 DIN 6799	3	
60	207 956 346	COMPLETE LEVER	1	
61	000 015 994	CATCH	1	
62	105 800 953	PIN	1	
63	000 045 639	DRAW BAR	1	0-8045-237
64	000 001 485	SPRING	1	0-9746-439
65	275 200 006	STIRRUP RING 6 DIN 6799	1	
66	000 784 256	MOWING LIFTING HANDLE	1	0-5700-015
67	000 403 535	PUSH BUTTON	1	0-5900-055
70	207 956 349	TOP ROD	1	9-5600-349
71	207 956 350	BOTTOM ROD	1	9-5600-350
72	207 056 915	ADJUSTING NUT	1	0-5600-915
73	000 272 503	NUT M8 DIN 934-KL.8	1	

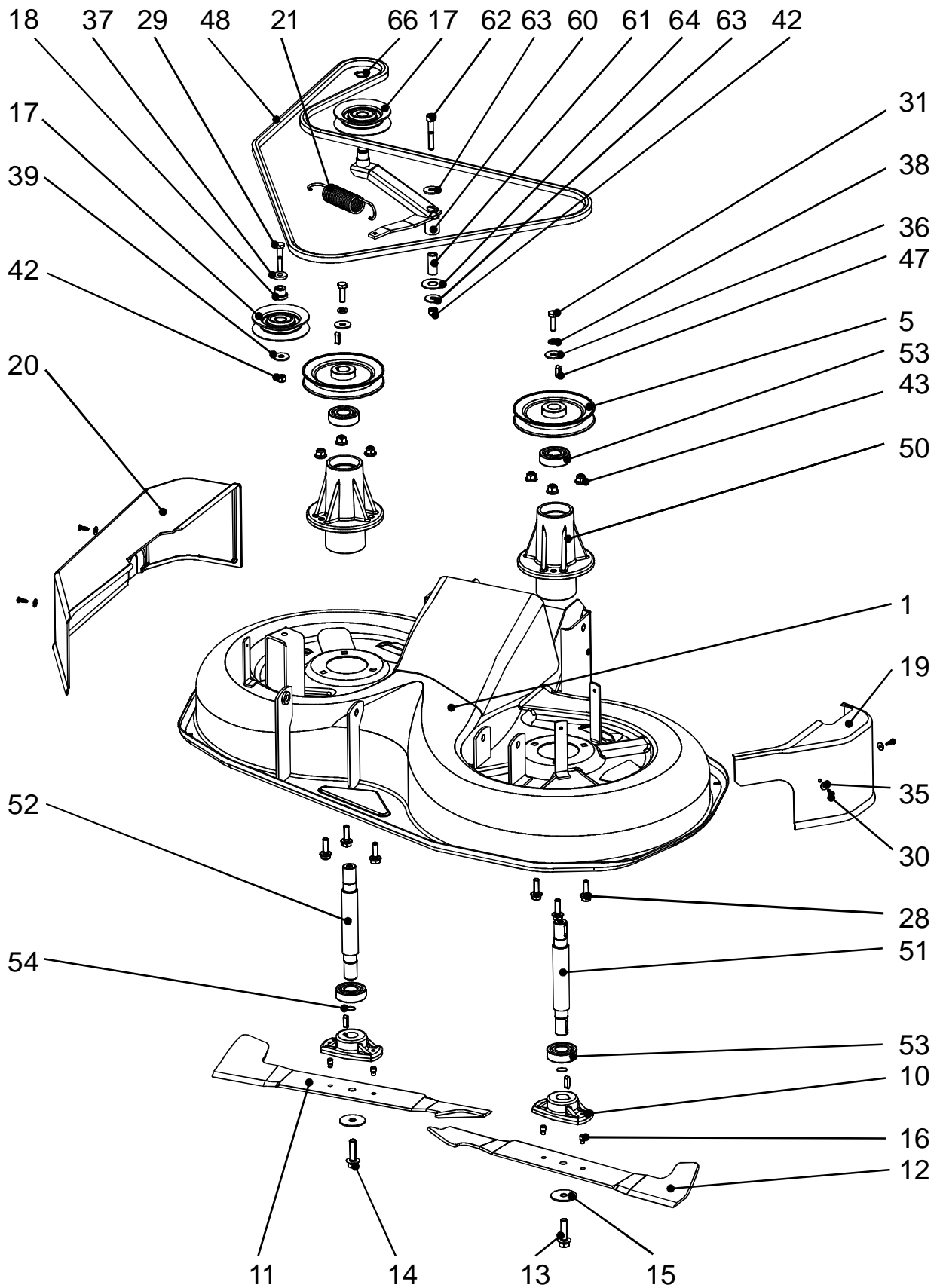

ASSEMBLY "6" CUTTING PAN-MOWER HOUSING COMPL.

position	part no.	name	qty.	drawing no.
1	207 956 295	MOWING COVER 92 COMPLETE	1	9-5600-295
5	207 959 348	MOWING BELT PULLEY 4,5"	2	9-5900-348
10	207 056 846	FLANGE	2	0-5600-846
11	207 056 854	RIGHT KNIFE 460 "K	1	0-5600-854
12	207 056 853	LEFT KNIFE 460 "K	1	0-5600-853
13	000 233 453	HEX SCREW M10x1x35	1	0-9011-287
14	000 245 025	HEX SCREW M10x1x35L	1	0-9011-283
15	505 900 073	DISC SPRING 10,2x40x2x3	1	0-5900-073
16	000 281 490	SHEAR PIN	4	0-9311-736
17	205 059 069	BELT PULLEY W3500-3712 (CAPITOL)	2	0-5900-069
18	105 800 931	PIN	4	0-5800-931
19	207 056 852	LEFT COVER	1	0-5600-852
20	207 056 855	RIGHT COVER	1	0-5600-855
21	207 056 856	SPRING (TZ 315.283.1103)	1	0-5600-856
28	000 213 312	HEX SCREW M8x25 DIN 6921	6	
29	207 204 159	HEX SCREW M8x40 DIN 931-8,8	1	
30	300 000 012	HEX SCREW 4,2 x13 DIN 7981 C shape	4	
31	000 246 235	HEX SCREW M8x25 DIN 933-8,8	2	
35	000 200 090	WASHER 4.3 DIN 9021 B	4	
36	207 036 163	WASHER DIN 440 R/VZ 9	2	
37	000 298 761	WASHER 8.4 DIN 7349	1	
38	000 201 003	WASHER 8 DIN 127 B	2	
39	000 291 500	WASHER 8,4 DIN 125 A	1	
42	000 280 885	NUT M8 DIN985-KL.8	1	
43	252 108 008	NUT M8 DIN 6926	6	
47	207 069 001	SPRING 6h9x6x20 ČSN022562	4	
48	207 100 453	DOUBLE WEDGE BELT AA 80 A5D	1	
50	207 056 840	BEARING BODY 92	2	0-5600-840
51	207 056 842	"L" SHAFT	1	0-5600-842
52	207 056 841	"P" SHAFT	1	0-5600-841
53	207 023 645	BEARING 6204 2RS	4	
54	207 230 231	RETAINING RING 20 DIN 471	2	
60	207 956 328	TENSIONER ARM	1	9-5600-328
61	207 056 874	SPACER	1	0-5600-874
62	207 204 158	HEX SCREW M8x50 DIN 912-8,8	1	
63	000 298 760	WASHER 8,4 DIN 9021 B	2	
64	207 036 167	WASHER 14 BN 735	1	
65	000 280 885	NUT M8 DIN 985-KL.8	1	
66	207 230 232	RETAINING RING 17 DIN 471	1	

OPERATION - TRAVEL PEDALS

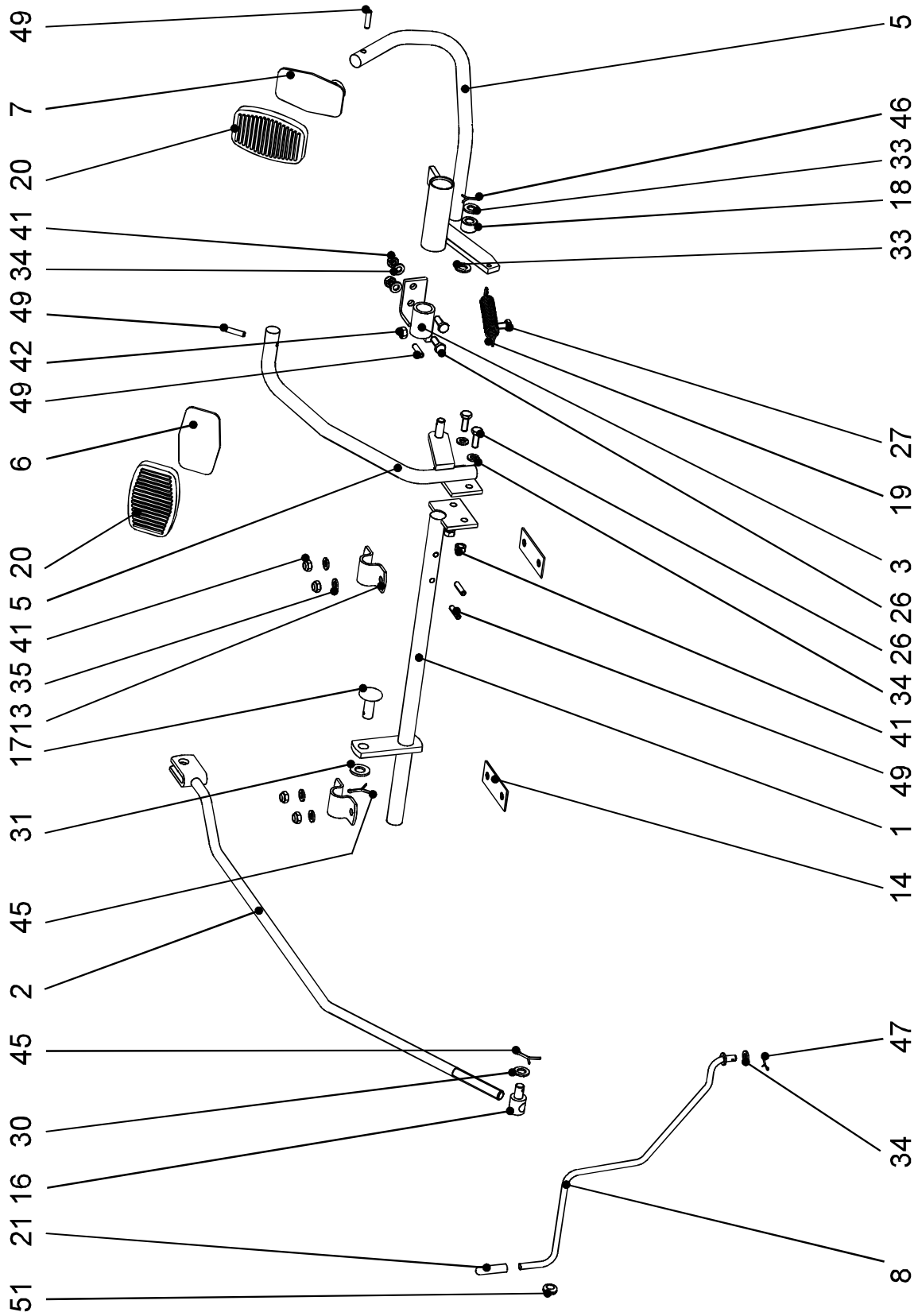

ASSEMBLY "7"

OPERATION TRAVEL PEDALS

position	part no.	name	qty.	drawing no.
1	207 956 249	COMPLETE SHAFT	1	9-5600-249
2	207 956 247	COMPLETE CONTROL ROD	1	9-5600-247
3	207 956 255	COMPLETE HOLDER	1	9-5600-255
4	207 956 253	TRAVEL PEDAL	1	9-5600-253
5	207 956 244	COMPLETE REVERSE PEDAL	1	9-5600-244
6	207 956 248	PEDAL	1	9-5600-248
7	207 956 245	REVERSE PEDAL	1	9-5600-245
8	207 956 246	COMPLETE BY-PASS ROD	1	9-5600-246
13	207 055 007	STIRRUP	1	0-5600-927
14	207 055 030	WASHER	1	0-5500-030
16	200 058 618	CONTROL PIN	1	0-5800-618
17	200 058 594	FORK PIN	1	0-5800-594
18	202 056 016	ROLL	1	0-5600-016
19	207 055 046	SPRING	1	0-5500-046
20	000 406 901	PEDAL SKIN	1	0-5800-115
21	204 056 342	RIGHT CAP 6/30	1	0-5600-342
26	000 284 449	HEX SCREW M6x16 DIN 933-8.8	4	
27	204 206 201	HEX SCREW M6x20 DIN 933-8.8	1	
30	200 296 000	WASHER 9 DIN 126	1	
31	000 292 061	WASHER 10.5 DIN 125 A	1	
33	000 291 500	WASHER 8,4 DIN 125 A	2	
34	000 290 389	WASHER 6.4 DIN 125 A	4	
35	000 200 442	WASHER 6.4 DIN 127 B	6	
41	000 283 118	NUT M6 DIN 985-KL.8	8	
42	000 271 942	NUT M6 DIN 934	1	
45	000 255 530	COTTER PIN 2,5x18 DIN 94	2	
46	200 282 218	COTTER PIN 2x18 DIN 94	1	
47	200 258 742	COTTER PIN 1,6x12 DIN94	1	
49	000 291 610	PIN 5x22 DIN 1481	4	
51	207 100 455	BUSH 7x4 ČSN 633881.1	1	

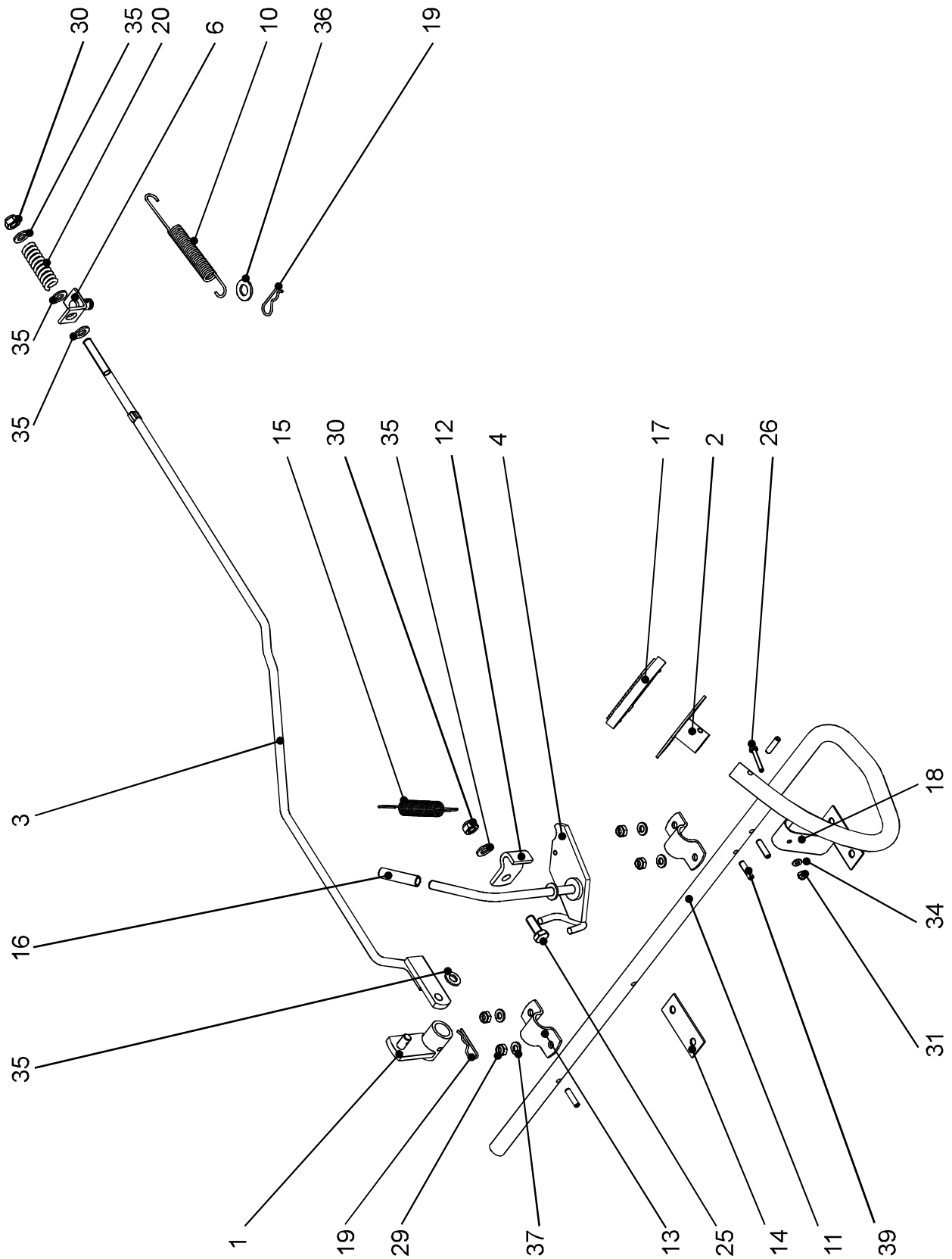

ASSEMBLY "8"

OPERATION BRAKE

position	part no.	name	qty.	drawing no.
1	200 958 754	TT BRAKE LEVER	1	9-5800-754
2	207 956 386	BRAKE PEDAL	1	9-5600-386
3	207 956 387	COMPLETE BRAKE ROD	1	9-5600-387
4	207 956 388	MINI ARRESTING LEVER	1	9-5600-388
6	200 958 761	COMPLETE FOOT	1	9-5800-761
10	000 013 530	SPRING	1	0-9746-445
11	207 055 052	MINI BRAKE PEDAL	1	0-5500-052
12	000 048 400	HOLDER	1	0-8041-236
13	207 056 927	STIRRUP	2	0-5600-927
14	207 055 030	WASHER	2	0-5500-030
15	000 060 280	SPRING	1	0-9746-444
16	000 406 560	BRAKE ARRESTING LEVER SKIN	1	0-5800-114
17	000 406 901	PEDAL SKIN	1	0-5800-115
18	105 800 975	FLEXIBLE LEVER	1	0-5800-975
19	200 059 136	FLEXIBLE COTTER PIN 1,8-36	2	0-5900-136
20	000 054 340	SPRING	1	0-5800-979
25	000 244 563	HEX SCREW M8x20 DIN 933-8,8	1	
26	220 004 025	HEX SCREW M4x25 DIN 933-8,8	1	
29	000 283 118	NUT M6 DIN 985-KL.8	4	
30	000 280 885	NUT M8 DIN 985-KL.8	2	
34	000 200 090	WASHER 4.3 DIN 125 A	1	
35	000 291 500	WASHER 8,4 DIN 125 A	5	
36	000 292 061	WASHER 10.5 DIN 125 A	1	
37	000 200 442	WASHER 6 DIN 127B	4	
39	000 291 610	PIN 5x22 DIN 1481	4	

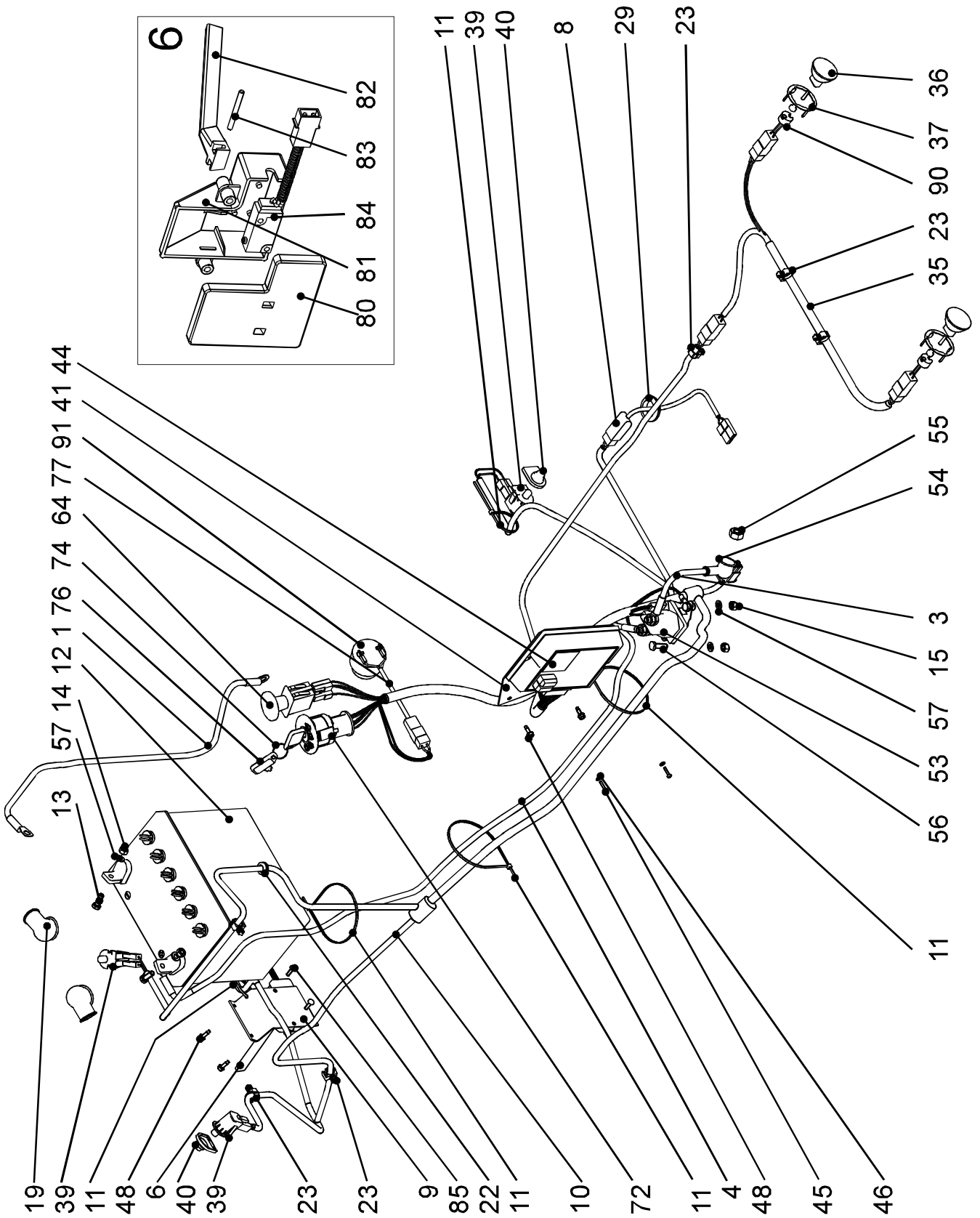

ASSEMBLY "9" ELECTRICAL WIRING HARNESS COMPL.

position	part no.	name	qty.	drawing no.
1	207 956 389	"-" MINI BATTERY CABLE	1	9-5600-389
3	207 956 361	MINI SOLENOID CABLE	1	9-5600-361
4	207 056 362	"+" MINI BATTERY CABLE	1	9-5600-362
6	200 958 656	CONTAINER FILLING SWITCH	1	9-5800-292
8	207 956 359	MINI DIODE BUNDLE	1	9-5600-359
9	207 056 935	COVER		0-5600-935
10	207 956 360	MINI CABLE BUNDLE	1	9-5600-360
11	000 323 356	CABEL CLAMP RT 360	3	0-5800-256
12	000 866 712	BATTERY 12V -22Ah 7AL	1	
13	000 284 449	HEX SCREW M 6x16 DIN 933	2	
14	000 271 942	NUT M6 DIN 934	2	
15	000 283 118	NUT M6 DIN 985-KL.8	2	
19	000 652 388	BATTERY CAP 16x15,4	2	
22	000 430 595	BUSH 9x1,5 KD 712	1	
23	000 829 191	CLOSING CLAMP 1903-00-F/A	5	
29	000 820 699	BUSH 23x2 KD5	1	
35	207 956 358	MINI LIGH BULB BUNDLE	1	9-5600-358
36	207 100 452	HALOGEN BULB 35mm 12V20W30°	2	
37	207 100 450	LIGHT BULB SLEEVE MR11 (Ø30)	2	
39	000 877 943	DELTA SWITCH 6440 -04	3	0-5900-008
40	505 900 049	DELTA COVER 9910	2	0-5900-049
41	207 056 934	MODULE HOLDER	1	0-5600-934
44	204 958 025	STEERING MODULE HYDRO-05	1	9-5800-025
45	204 958 025	HEX SCREW 2,9x13 DIN 7981 SHAPE Z	2	
46	201 852 334	WASHER 3 DIN 125 A	2	
48	000 259 314	HEX SCREW 4,2x13 eco-drill DIN 7504 K	4	
53	000 821 117	SOLENOID 94255/12V-150A	1	
54	000 453 332	STARTER CAP 16x11	1	
55	000 277 816	NUT W 1/4-20	1	
56	000 247 357	HEX SCREW M6x12 DIN 933-8,8	2	
57	000 290 389	WASHER 6.4 DIN 125 A	4	
64	204 059 307	CLUTCH PULL SWITCH	1	
72	200 830 600	SWITCHING BOX DELTA PN 6900-47 M	1	
74	000 304 909	RING 406 15/40	1	
76	200 800 001	SWITCHING KEY 803 781	2	
77	201 958 410	COMPLETE BUZZER	1	
80	201 058 120	SWITCH BOTTOM PART	1	
81	201 058 121	SWITCH TOP PART	1	0-5800-121
82	201 058 119	SWITCH LEVER	3	0-5800-119
83	200 059 134	SWITCH PIN	1	0-5900-134
84	200 810 845	SWITCH D2 VW-5-1M (1539 RC1)	1	
85	000 259 314	HEX SCREW 4,2x13 DIN 7981 SHAPE F	2	
90	000 858 000	LIGHT BULB CAP G 4	2	
91	201 852 002	BUZZER 11 PN 3120/12V DC	1	

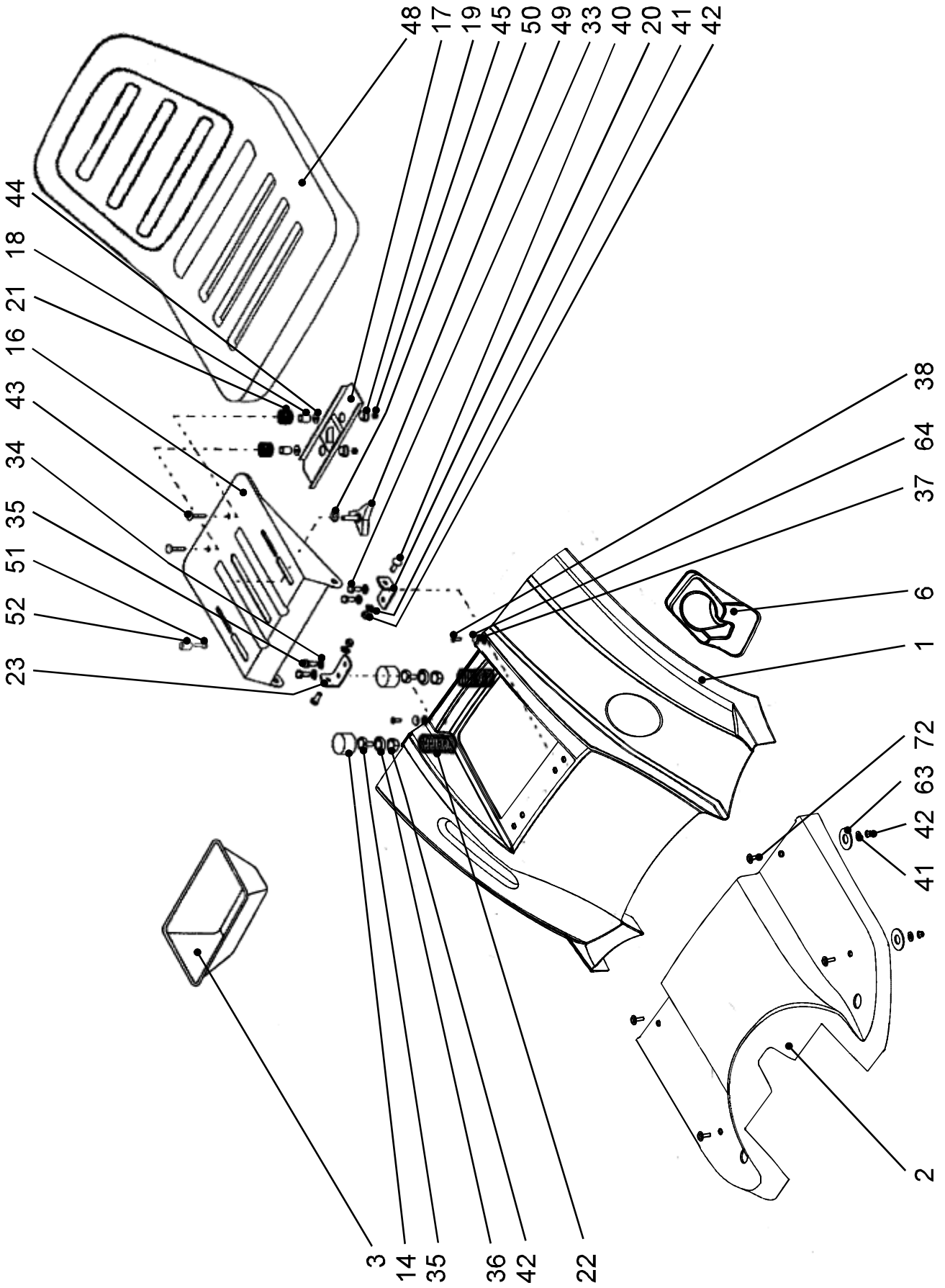

ASSEMBLY "10"

BODY ASSY FENDER SEAT

position	part no.	name	qty.	drawing no.
1	207 056 967	BUMPER HYDRO MINI - ORANGE	1	0-5600-967
2	207 056 895	MINICUT FLOOR	1	0-5600-895
3	207 056 896	BATTERY COMPARTMENT	1	0-5600-896
6	207 055 144	DRINK COMPARTMENT	1	0-5500-144
14	000 407 121	Cap SC 1 1/2	2	
16	105 800 939	SEAT CARRIER	1	0-5800-939
17	105 800 938	SWITCH SUPPORT	1	0-5800-938
18	105 800 935	SPACER	2	0-5800-935
19	000 002 156	CASE	2	0-9421-424
20	207 056 900	CARRIER HOLDER "L"	2	0-5600-900
21	000 331 386	SEAT SPRING	2	0-5900-011
22	000 098 692	SPRING	2	0-9746-434
23	207 056 899	CARRIER HOLDER "P"	1	0-5600-899
33	000 246 235	HEX SCREW M8x25 DIN 933-8,8	1	
34	000 201 003	WASHER 8 DIN 127 B	4	
35	000 244 563	HEX SCREW M8x20 DIN 9338.8	5	
36	000 298 760	WASHER 8,4 DIN 9021 B	2	
37	000 268 774	WASHER 5.3 SN 213,912	2	
38	204 200 001	HEX SCREW M 5x16 DIN 7991 - 10,9	2	
40	000 074 690	SEAT SUPPORT SCREW	2	0-5800-927
41	000 291 500	WASHER 8,4 DIN 125 A	6	
42	000 280 885	NUT M8 DIN 985 KL.8	8	
43	240 306 030	HEX SCREW M6x30 DIN 603 -6,8	2	
44	000 298 210	WASHER 6.4 DIN 9021 B	2	
45	000 283 118	NUT M6 DIN 985 KL.8	2	
48	206 059 127	SEAT INI 054 (met. zav.)	1	0-5900-127
49	203 150 000	ADJUSTING SCREW KRG 1A 40 M8x15	2	
50	000 290 642	FLEXIBLE WASHER 8 DIN 137 A	2	
51	222 008 020	BOLT M8x20 DIN 6921-8,8	2	
52	201 058 223	SPACER	2	0-5800-223
63	105 800 864	WASHER 10,5/20/2	2	0-5800-864
64	105 800 862	WASHER 5	8	0-5800-862
68	254 505 016	HEX SCREW M5x16 DIN 965 A -4,8	2	
72	205 204 139	HEX SCREW M8x20 BN 11252-10.9	4	

BODY ASSEMBLY - HOOD

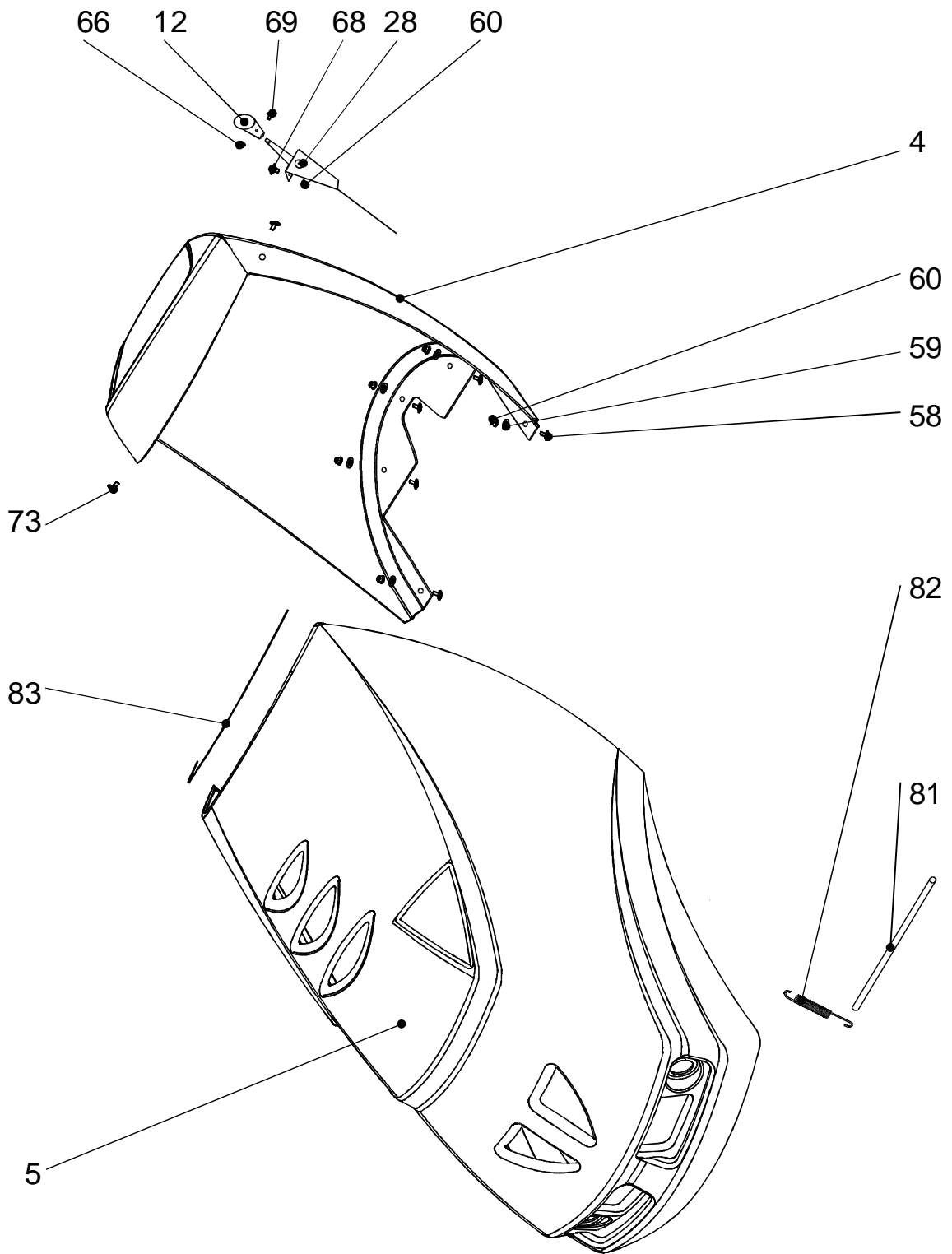

ASSEMBLY "10"

BODY ASSEMBLY HOOD

position	part no.	name	qty.	drawing no.
4	207 056 898	MINICUT PANEL	1	0-5600-898
5	207 956 340	HOOD MINI 1/orange	1	9-5600-342
12	000 084 414	GAS LEVER	1	0-5700-016
28	000 717 739	GAS LEVER WITH STRANGLER "37"	1	9-5900-202
58	220 005 020	HEX SCREW M5x20 DIN 933 -8,8	5	
59	000 239 448	WASHER 5.3 DIN 9021 B	5	
60	000 285 912	NUT M5 DIN985-KL.8	5	
66	000 284 240	NUT M4 DIN985-KL.8	1	
68	254 505 016	HEX SCREW M5x16 DIN 965 A -4,8	2	
69	250 004 014	HEX SCREW M4x14 DIN 84 A	1	
73	207 204 153	HEX SCREW M6x12 BN 354-4,6	2	
81	105 800 818	SPRING HOLDER	1	0-5800-818
82	105 800 801	HOOD SPRING	1	0-5800-801
83	207 056 903	MOULDING 8/2	1	0-5600-903

GRASS COLLECTOR ASSEMBLY

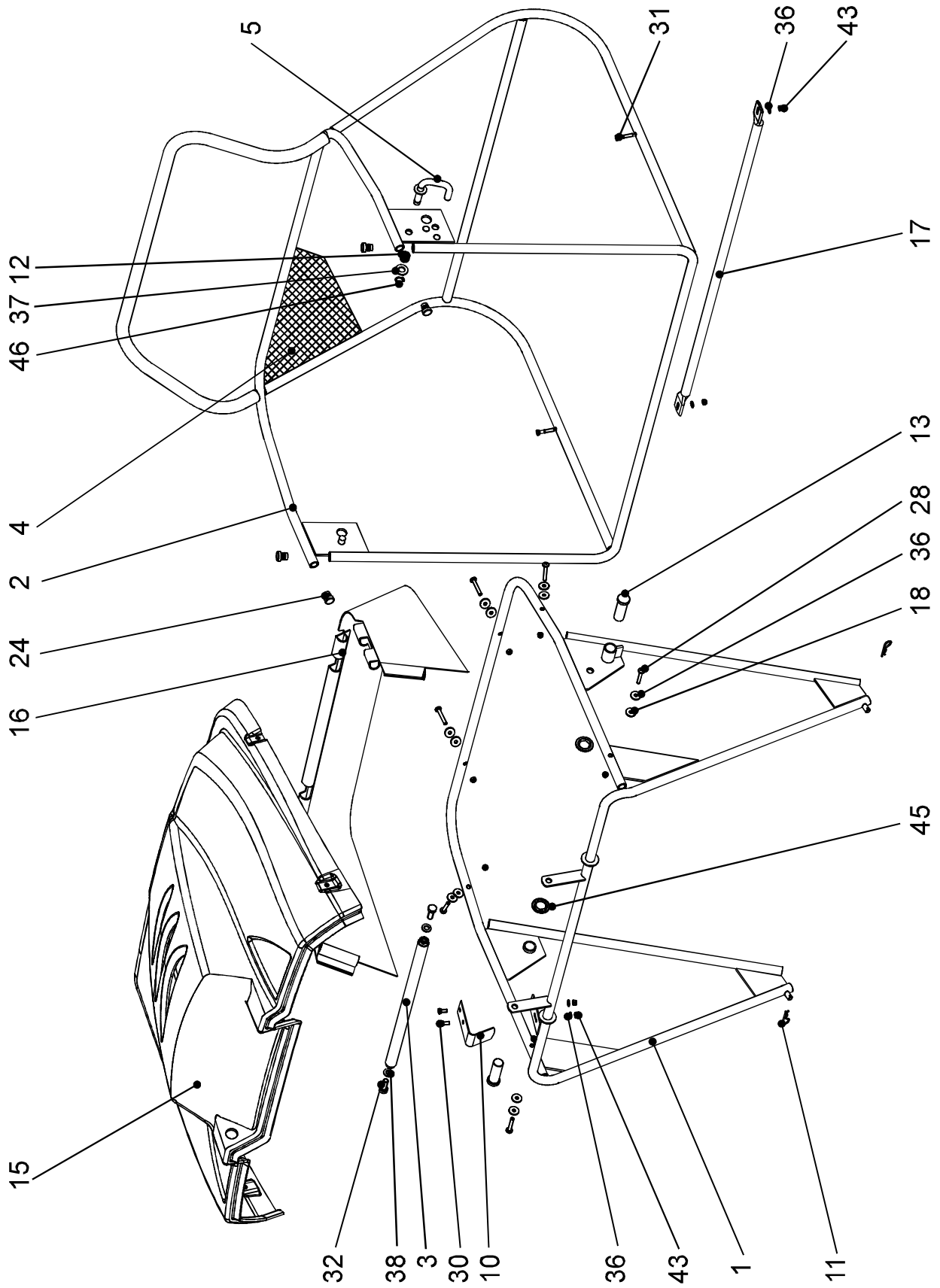

ASSEMBLY "11"

GRASS COLLECTOR ASSY.

position	part no.	name	qty.	drawing number
1	207 956 404	CONTAINER FRAME SOLID PART	1	9-5600-404
2	207 956 407	CONTAINER FRAME TILTABLE PART	1	9-5600-407
3	207 956 409	COMPLETE HANDLE	1	9-5600-409
4	207 956 414	CONTAINER SKIN MINI	2	9-5600-414
5	207 956 410	ARRESTING	1	9-5600-410
10	207 055 056	SWITCH CONTACT	1	0-5500-056
11	200 059 136	FLEXIBLE COTTER PIN 1,8-36	2	0-5900-136
12	207 056 979	CONTAINER ARRESTING SPRING	1	0-5600-979
13	207 055 057	TILTING PIN	2	0-5500-057
15	207 056 642	CONTAINER COVER "ORANGE" RAL 2014	1	0-5600-642
16	207 055 151	SCREEN	1	0-5500-151
17	207 056 641	BOTTOM REINFORCEMENT	1	0-5600-641
18	105 800 862	WASHER 5	6	0-5800-862
24	207 023 643	CAP GL 15x2-2,5	4	
28	207 204 152	HEX SCREW M5x30 DIN 7985 A -4,8	6	
29	207 204 154	HEX SCREW M5x14 DIN912	2	
30	207 204 160	HEX SCREW M5x10 DIN 933-8,8	2	
33	000 286 605	HEX SCREW M5x25 DIN 933 -8,8	2	
36	000 289 828	WASHER 5.3 DIN 125 A	6	
37	000 292 061	WASHER 10.5 DIN 125 A	1	
38	000 201 003	WASHER 8 DIN 127 B	2	
43	000 285 912	NUT M5 DIN 985-KL.8	10	
45	207 230 233	LOCK RING 16 (STARLOCK)	2	
46	202 845 367	RETAINING RING 10 DIN 471	1	

CHUTE - COLLECTOR ASSEMBLY

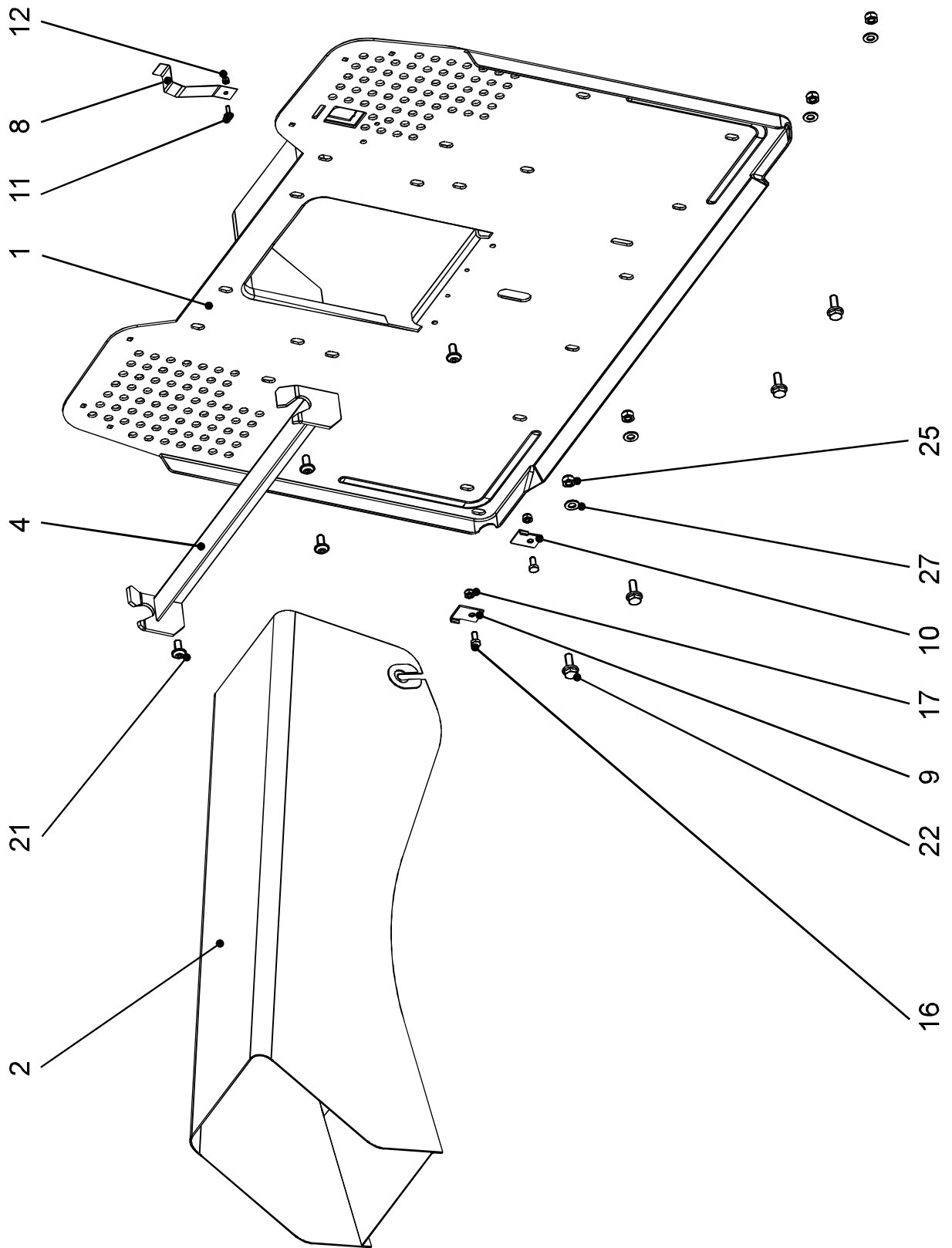

ASSEMBLY "12"

CHUTE-COLLECTOR ASSEMBLY

position	part no.	name	qty.	drawing no.
1	207 956 336	COMPLETE CONTAINER PLATE MINI	1	9-5600-336
2	207 956 337	TUNNEL MINI	1	9-5600-337
4	207 956 338	COMPLETE CONTAINER SUSPENSION	1	9-5600-338
8	105 800 926	CONTAINER DESK	1	0-5800-926
9	207 056 888	"L" GUIDE	1	0-5600-888
10	207 056 889	"P" GUIDE	1	0-5600-889
11	253 504 012	SCREW M4x12 eco-fix 4,8	1	
12	000 284 240	NUT M4 DIN 985-KL.8	1	
16	000 247 357	HEX SCREW M6x12 DIN 933-8,8	2	
17	000 283 118	NUT M6 DIN 985-KL.8	2	
21	255 108 016	HEX SCREW M8x16 BN 11252- 10,9	4	
22	207 204 156	HEX SCREW M8x16 DIN 6921-8,8	4	
25	000 280 885	NUT M8 DIN 985-KL.8	4	
27	000 291 500	WASHER 8,4 DIN 125 A	4	

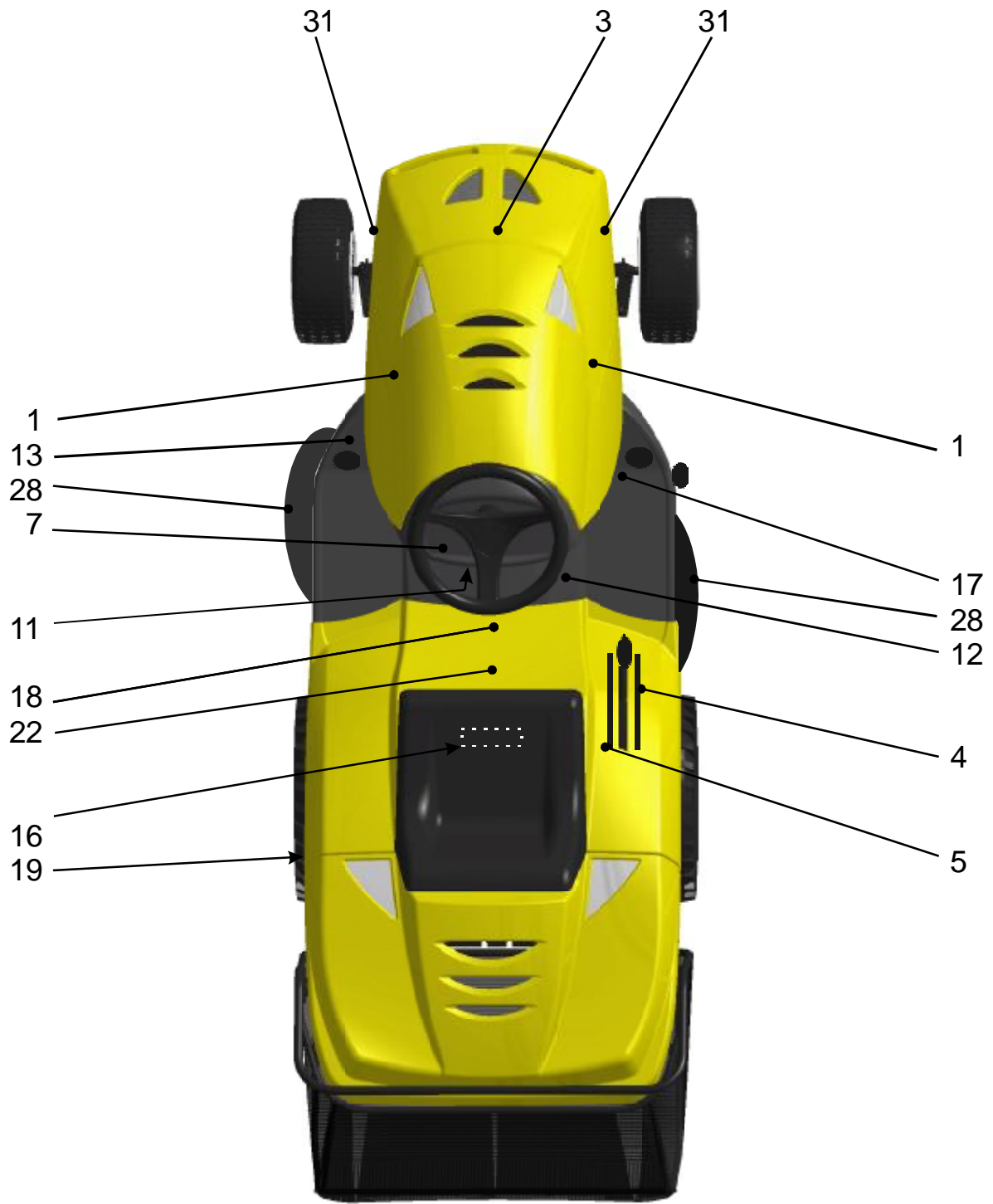

ASSEMBLY "13"

DECALS LABELS

position	part no.	name	qty.	drawing no.
1	204 056 450	AMA HOOD SIDE LABELS	2	0-5600-450
3	204 056 451	AMA HOOD FRONT LABELS	1	0-5600-451
4	207 056 878	MOWING LIFTING LABEL "P"	1	0-5600-878
5	207 056 879	MOWING LIFTING LABEL "L"	1	0-5600-879
7	207 056 880	MINICUT PANEL LABEL	1	0-5600-880
11	000 686 620	OPERATING INSTRUCTIONS	1	0-5600-296
12	000 668 041	SAFETY INSTRUCTIONS LABEL	1	0-5600-294
13	000 689 315	"BRAKE ARRESTING" LABEL	1	0-5600-293
16	204 056 298	BATTERY LABEL	1	0-5600-298
17	207 048 739	TRAVEL LABEL	1	0-4800-739
18	201 058 186	ATTENTION LABEL	1	0-5800-186
22	505 900 075	B&S Label	1	0-5900-075
28	000 601 920	MOWING SAFETY LABEL	2	0-5600-290
31	207 056 795	AMA 130-92 TYPE LABEL	1	0-5600-795

FRAME

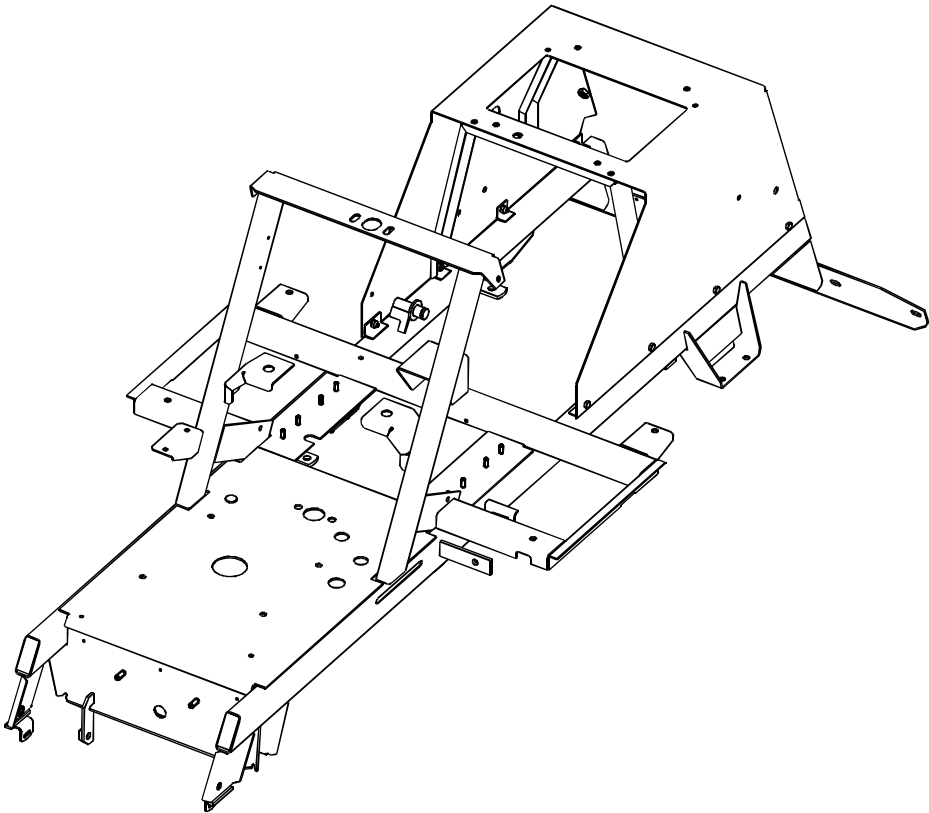

ASSEMBLY "15"

FRAME

position	part no.	name	qty.	drawing no.
1	207 956 303	MINI FRAME	1	9-5600-303
